



FLEX I/O Digital Sourcing Input and Sinking Output Modules

Cat. No. 1794-IV16, -OV16, and -OV16P

Important User Information

Solid state equipment has operational characteristics differing from those of electromechanical equipment. *Safety Guidelines for the Application, Installation and Maintenance of Solid State Controls* (Publication SGI-1.1 available from your local Rockwell Automation sales office or online at <http://www.ab.com/manuals/gi>) describes some important differences between solid state equipment and hard-wired electromechanical devices. Because of this difference, and also because of the wide variety of uses for solid state equipment, all persons responsible for applying this equipment must satisfy themselves that each intended application of this equipment is acceptable.



In no event will Rockwell Automation, Inc. be responsible or liable for indirect or consequential damages resulting from the use or application of this equipment.

The examples and diagrams in this manual are included solely for illustrative purposes. Because of the many variables and requirements associated with any particular installation, Rockwell Automation, Inc. cannot assume responsibility or liability for actual use based on the examples and diagrams.

No patent liability is assumed by Rockwell Automation, Inc. with respect to use of information, circuits, equipment, or software described in this manual.

Reproduction of the contents of this manual, in whole or in part, without written permission of Rockwell Automation, Inc. is prohibited.

Throughout this manual we use notes to make you aware of safety considerations.

WARNING 	Identifies information about practices or circumstances that can cause an explosion in a hazardous environment, which may lead to personal injury or death, property damage, or economic loss.
IMPORTANT	Identifies information that is critical for successful application and understanding of the product.
ATTENTION 	Identifies information about practices or circumstances that can lead to personal injury or death, property damage, or economic loss. Attentions help you: <ul style="list-style-type: none"> • identify a hazard • avoid a hazard • recognize the consequence

WARNING 	When you insert or remove the module while backplane power is on, an electrical arc can occur. This could cause an explosion in hazardous location installations. Be sure that power is removed or the area is nonhazardous before proceeding.
---	--

ATTENTION 	FLEX I/O is grounded through the DIN rail to chassis ground. Use zinc plated yellow-chromate steel DIN rail to assure proper grounding. The use of other DIN rail materials (e.g. aluminum, plastic, etc.) that can corrode, oxidize, or are poor conductors, can result in improper or intermittent grounding.
---	---

ATTENTION



Environment and Enclosure

This equipment is intended for use in a Pollution Degree 2 industrial environment, in overvoltage Category II applications (as defined in IEC publication 60664-1), at altitudes up to 2000 meters without derating.

This equipment is considered Group 1, Class A industrial equipment according to IEC/CISPR Publication 11. Without appropriate precautions, there may be potential difficulties ensuring electromagnetic compatibility in other environments due to conducted as well as radiated disturbance.

This equipment is supplied as "open type" equipment. It must be mounted within an enclosure that is suitably designed for those specific environmental conditions that will be present and appropriately designed to prevent personal injury resulting from accessibility to live parts. The interior of the enclosure must be accessible only by the use of a tool. Subsequent sections of this publication may contain additional information regarding specific enclosure type ratings that are required to comply with certain product safety certifications.

See NEMA Standards publication 250 and IEC publication 60529, as applicable, for explanations of the degrees of protection provided by different types of enclosure. Also, see the appropriate sections in this publication, as well as the Allen-Bradley publication 1770-4.1 ("Industrial Automation Wiring and Grounding Guidelines"), for additional installation requirements pertaining to this equipment.

ATTENTION



Preventing Electrostatic Discharge

This equipment is sensitive to electrostatic discharge, which can cause internal damage and affect normal operation. Follow these guidelines when you handle this equipment:

- Touch a grounded object to discharge potential static.
- Wear an approved grounding wriststrap.
- Do not touch connectors or pins on component boards.
- Do not touch circuit components inside the equipment.
- If available, use a static-safe workstation.

European Hazardous Location Approval

The following modules are European Zone 2 approved: 1794-IV16, 1794-OV16 and 1794-OV16P.

European Zone 2 Certification

This equipment is intended for use in potentially explosive atmospheres as defined by European Union Directive 94/9/EC.

The LCIE (Laboratoire Central des Industries Electriques) certifies that this equipment has been found to comply with the Essential Health and Safety Requirements relating to the design and construction of Category 3 equipment intended for use in potentially explosive atmospheres, given in Annex II to this Directive. The examination and test results are recorded in confidential report No. 28 682 010.

Compliance with the Essential Health and Safety Requirements has been assured by compliance with EN 50021.



IMPORTANT

Observe the following additional Zone 2 certification requirements.

- This equipment is not resistant to sunlight or other sources of UV radiation.
- The secondary of a current transformer shall not be open-circuited when applied in Class I, Zone 2 environments.
- Equipment of lesser Enclosure Type Rating must be installed in an enclosure providing at least IP54 protection when applied in Class I, Zone 2 environments.
- This equipment shall be used within its specified ratings defined by Allen-Bradley.
- Provision shall be made to prevent the rated voltage from being exceeded by transient disturbances of more than 40% when applied in Class I, Zone 2 environments

North American Hazardous Location Approval

The following modules are North American Hazardous Location approved: 1794-IV16, 1794-OV16 and 1794-OV16P.

The following information applies when operating this equipment in hazardous locations:		Informations sur l'utilisation de cet équipement en environnements dangereux :	
<p>Products marked "CL I, DIV 2, GP A, B, C, D" are suitable for use in Class I Division 2 Groups A, B, C, D, Hazardous Locations and nonhazardous locations only. Each product is supplied with markings on the rating nameplate indicating the hazardous location temperature code. When combining products within a system, the most adverse temperature code (lowest "T" number) may be used to help determine the overall temperature code of the system. Combinations of equipment in your system are subject to investigation by the local Authority Having Jurisdiction at the time of installation.</p>		<p>Les produits marqués "CL I, DIV 2, GP A, B, C, D" ne conviennent qu'à une utilisation en environnements de Classe I Division 2 Groupes A, B, C, D dangereux et non dangereux. Chaque produit est livré avec des marquages sur sa plaque d'identification qui indiquent le code de température pour les environnements dangereux. Lorsque plusieurs produits sont combinés dans un système, le code de température le plus défavorable (code de température le plus faible) peut être utilisé pour déterminer le code de température global du système. Les combinaisons d'équipements dans le système sont sujettes à inspection par les autorités locales qualifiées au moment de l'installation.</p>	
<p>WARNING</p> 	<p>EXPLOSION HAZARD</p> <ul style="list-style-type: none"> • Do not disconnect equipment unless power has been removed or the area is known to be nonhazardous. • Do not disconnect connections to this equipment unless power has been removed or the area is known to be nonhazardous. Secure any external connections that mate to this equipment by using screws, sliding latches, threaded connectors, or other means provided with this product. • Substitution of components may impair suitability for Class I, Division 2. • If this product contains batteries, they must only be changed in an area known to be nonhazardous. 	<p>AVERTISSEMENT</p> 	<p>RISQUE D'EXPLOSION</p> <ul style="list-style-type: none"> • Couper le courant ou s'assurer que l'environnement est classé non dangereux avant de débrancher l'équipement. • Couper le courant ou s'assurer que l'environnement est classé non dangereux avant de débrancher les connecteurs. Fixer tous les connecteurs externes reliés à cet équipement à l'aide de vis, loquets coulissants, connecteurs filetés ou autres moyens fournis avec ce produit. • La substitution de composants peut rendre cet équipement inadapté à une utilisation en environnement de Classe I, Division 2. • S'assurer que l'environnement est classé non dangereux avant de changer les piles.

Installing Your Digital Module

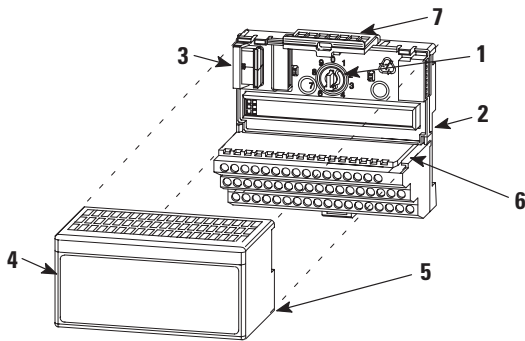

The module mounts on a 1794 terminal base.

ATTENTION



During mounting of all devices, be sure that all debris (metal chips, wire strands, etc.) is kept from falling into the module. Debris that falls into the module could cause damage on power up.

1. Rotate the keyswitch (1) on the terminal base (2) clockwise to position 2 as required for this type of module.

2. Make certain the flexbus connector (3) is pushed all the way to the left to connect with the neighboring terminal base/adaptor. **You cannot install the module unless the connector is fully extended.**
3. Make sure the pins on the bottom of the module are straight so they will align properly with the connector in the terminal base.

WARNING



If you remove or insert the module while the backplane power is on, an electrical arc can occur. This could cause an explosion in hazardous location installations. Be sure that power is removed or the area is nonhazardous before proceeding.

4. Position the module (4) with its alignment bar (5) aligned with the groove (6) on the terminal base.
5. Press firmly and evenly to seat the module in the terminal base unit. The module is seated when the latching mechanism (7) is locked into the module.

Connecting Wiring for the 1794-IV16, -OV16, and -OV16P (using a 1794-TB3 or -TB3S Terminal Base Unit)

1. Connect individual input or output wiring to numbered terminals on the 0-15 row (A) as indicated in the table below.
2. **1794-IV16** - Connect the associated input device common to the corresponding terminal on the 16-33 row (B) for each input as indicated in the table below. (Commons are internally connected together.) If using 3-wire input devices, also connect the associated input power lead to the corresponding terminal on the 34-51 row (C). **1794-OV16, -OV16P** - Connect the associated +V dc power lead of the output device to the corresponding terminal on the 34-51 row (C) for each output as indicated in the table below. (The +V power terminals of row (C) are internally connected together.)
3. Connect +V dc power to terminal 34 on the 34-51 row (C).
4. Connect dc common to terminal 16 on the 16-33 row (B).
5. If daisy chaining power to the next terminal base, connect a jumper from terminal 51 (+V dc) on this base unit to terminal 34 on the next base unit.
6. If continuing dc common to the next base unit, connect a jumper from terminal 33 (common) on this base unit to terminal 16 on the next base unit.

Note: The total current draw through any terminal base unit is limited to 10A. Separate power connections may be required.

Wiring Connections for the 1794-IV16, 1794-OV16 and 1794-OV16P

Channel	Signal	Power Terminal	Common Terminal ¹
		1794-OV16, 1794-OV16P, 1794-IV16 ¹	1794-IV16
0	A-0	C-35	B-17
1	A-1	C-36	B-18
2	A-2	C-37	B-19
3	A-3	C-38	B-20
4	A-4	C-39	B-21
5	A-5	C-40	B-22
6	A-6	C-41	B-23
7	A-7	C-42	B-24
8	A-8	C-43	B-25
9	A-9	C-44	B-26
10	A-10	C-45	B-27
11	A-11	C-46	B-28
12	A-12	C-47	B-29
13	A-13	C-48	B-30
14	A-14	C-49	B-31
15	A-15	C-50	B-32
+V dc	C-34 thru C-51 are internally connected together		
Common	B-16 thru B-33 are internally connected together		

¹ 2-wire sourcing input devices use the input and common terminals.
 3-wire sourcing input devices use the input, common and power terminals.

1794-TB2, -TB3 and -TB3S Terminal Base Wiring for 1794-IV16, 1794-OV16 and 1794-OV16P

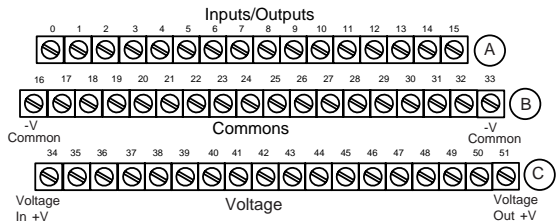

Connect V dc common to terminal B-16 (1794-TB3 shown)
 Connect +V dc power to terminal C-34
 (Use B-33 and C-51 for daisy-chaining to next terminal base unit)

2 and 3-Wire Input Wiring for 1794-IV16

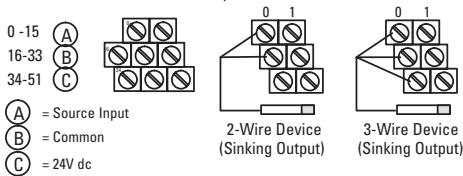

Configuring Your Input Module

You configure your input module by setting bits in the configuration word (word 3).

Dec.	15	14	13	12	11	10	9	8	7	6	5	4	3	2	1	0
Oct.	17	16	15	14	13	12	11	10	7	6	5	4	3	2	1	0
Read 0	I15	I14	I13	I12	I11	I10	I9	I8	I7	I6	I5	I4	I3	I2	I1	I0
Read 1	C = Counter Input value of input 15															
Write	Not used	CR	CF	NU	Input Filter FT 0-15	Not used										

Where I = Input
 C = Counter value for input 15
 FT = Input filter time
 CR = Counter Reset
 CF = Counter Fast - where 1 = Fast input (raw) data; 0 = Standard input filtered data
 NU = Not used
Note: C, CR and CF not available when used with any series 1794-ASB or -ASB2 Remote I/O Adapters.

Setting the Input Filter Time for the 1794-IV16

To set the input filter time, set the associated bits in the output image (complementary word) for the module.

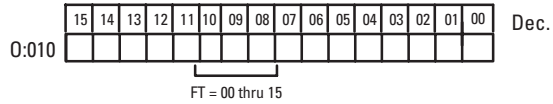

For example, to set a filter time of 8ms for a dc input module at address rack 1, module group 0, in configuration word 3, set bits 08, 09 and 10 as shown below.

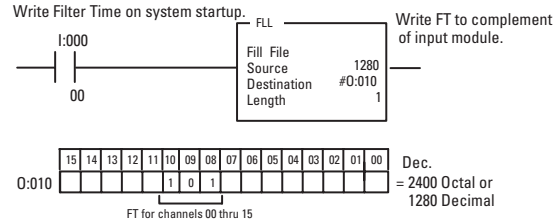

Refer to the table for additional filter times available.

Input Filter Times

Bits			Description	Selected Filter Time
10	09	08	Filter Time for inputs 00-15 (00-17)	
0	0	0	Filter Time 0 (Default)	0.25ms
0	0	1	Filter Time 1	0.50ms
0	1	0	Filter Time 2	1ms
0	1	1	Filter Time 3	2ms
1	0	0	Filter Time 4	4ms
1	0	1	Filter Time 5	8ms
1	1	0	Filter Time 6	16ms
1	1	1	Filter Time 7	32ms

Configuring Your Output Module

You configure your output module by setting bits in word 1.

Dec.	15	14	13	12	11	10	9	8	7	6	5	4	3	2	1	0
Oct.	17	16	15	14	13	12	11	10	7	6	5	4	3	2	1	0
Read 0	Not used															
Write 1	O15	O14	O13	O12	O11	O10	O9	O8	O7	O6	O5	O4	O3	O2	O1	O0
Where	O = Output															

Specifications

Specifications - 16 Source Input Module, Cat. No. 1794-IV16	
Number of Inputs	16, nonisolated, sourcing
Module Location	Cat. No. 1794-TB3, -TB3S
On-state Voltage	10V dc minimum 24V dc nominal 31.2V dc maximum
On-state Current	2.0mA minimum 8.0mA nominal at 24V dc 11.0mA maximum
Off-state Voltage	5.0V dc maximum
Off-state Current	1.5mA minimum
Input Impedance	4.7K ohms maximum
Isolation Voltage	Tested at 2121V dc for 1s between user and system No isolation between individual channels
Flexbus Current	30mA
Power Dissipation	5.7W maximum @ 31.2V dc
Thermal Dissipation	Maximum 19.4 BTU/hr @ 31.2V dc

Indicators (field side indication, customer device driven)	16 yellow status indicators
Input Filter Time ¹ Off to On On to Off	0.25ms, 0.5ms, 1ms, 2ms, 4ms, 8ms, 16ms, 32ms 0.25ms, 0.5ms, 1ms, 2ms, 4ms, 8ms, 16ms, 32ms 0.25ms default - Selectable using configuration word 3
¹ Input off-to-on filter time is the time from a valid input signal to recognition by the module. Input on-to-off filter time is time from the input signal dropping below the valid level to recognition by the module.	

Specifications - 16 Output Modules 1794-0V16 and -0V16P

	1794-0V16	1794-0V16P
Number of Outputs	16, nonisolated, sinking	
Module Location	Cat. No. 1794-TB3, -TB3S	
On-state Voltage Range	10V dc minimum 24V dc nominal 31.2V dc maximum	
Output Current Rating	8.0A (16 outputs @ 0.5A)	
Off-state Voltage	31.2 dc maximum	
On-state Current	1.0mA minimum per channel 500mA maximum per channel	
Surge Current	2A for 50ms, repeatable every 2s	
Off-state Leakage	0.5mA maximum	
On-state Voltage Drop	0.2V dc maximum	
Isolation Voltage	Tested at 2121V dc for 1s between user and system No isolation between individual channels	
Output Signal Delay ¹	Off to On - 0.5ms maximum On to Off - 1.0ms maximum	
Flexbus Current	80mA	
Power Dissipation	4.2W maximum @ 31.2V dc	
Thermal Dissipation	Maximum 14.3 BTU/hr @ 31.2V dc	
Indicators (field side indication, logic driven)	16 yellow status indicators	
Fusing	Module outputs are not fused. Fusing is recommended. If fusing is desired, you must provide external fusing. Use SAN-0 MQ4-800 800mA fuses	Outputs are electronically protected.
¹ The time from the receipt of an on or off command to the output actually turning on or off.		

General Specifications

Terminal Base Screw Torque	7 pound-inches (0.8Nm)
Dimensions (with module installed)	3.7H x 3.7W x 2.7D inches 94H x 94W x 69D mm
External dc power Supply voltage Voltage range	24V dc nominal 1794-0V16, -0V16P - 10.0 to 31.2V dc (includes 5% ac ripple) 1794-1V16 - 10 to 31.2V dc (includes 5% ac ripple) (see derating curve) 1794-0V16, -0V16P - 49mA @ 24V dc (21-65mA)
Supply current	
Keyswitch Position	2
Environmental Conditions	
Operating Temperature	IEC 60068-2-1 (Test Ad, Operating Cold), IEC 60068-2-2 (Test Bd, Operating Dry Heat), IEC 60068-2-14 (Test Nb, Operating Thermal Shock): 0 to 55°C (32 to 131°F)
Storage Temperature	IEC 60068-2-1 (Test Ab, Un-packaged Non-operating Cold), IEC 60068-2-2 (Test Bb, Un-packaged Non-operating Dry Heat), IEC 60068-2-14 (Test Na, Un-packaged Non-operating Thermal Shock): -40 to 85°C (-40 to 185°F)
Relative Humidity	IEC 60068-2-30 (Test Db, Un-packaged Non-operating Damp Heat): 5 to 95% non-condensing
Vibration	IEC60068-2-6 (Test Fc, Operating): 5g @ 10-500Hz
Shock	IEC60068-2-27 (Test Ea, Unpackaged shock): Operating 30g Non-operating 50g
Emissions	CISPR 11: Group 1, Class A (with appropriate enclosure)

www.rockwellautomation.com

Corporate Headquarters

Rockwell Automation, 777 East Wisconsin Avenue, Suite 1400, Milwaukee, WI, 53202-5302 USA, Tel: (1) 414.212.5200, Fax: (1) 414.212.5201

Headquarters for Allen-Bradley Products, Rockwell Software Products and Global Manufacturing Solutions

Americas: Rockwell Automation, 1201 South Second Street, Milwaukee, WI 53204-2496 USA, Tel: (1) 414.382.2000, Fax: (1) 414.382.4444
Europe: Rockwell Automation SA/NV, Vorstlaan/Boulevard du Souverain 36-BP 3A/B, 1170 Brussels, Belgium, Tel: (32) 2 663 0600, Fax: (32) 2 663 0640
Asia Pacific: Rockwell Automation, 27/F Citicorp Centre, 18 Whitfield Road, Causeway Bay, Hong Kong, Tel: (852) 2887 4788, Fax: (852) 2508 1846

Headquarters for Dodge and Reliance Electric Products

Americas: Rockwell Automation, 6040 Ponders Court, Greenville, SC 29615-4617 USA, Tel: (1) 864.297.4800, Fax: (1) 864.281.2433
Europe: Rockwell Automation, Brühlstraße 22, D-74834 Elztal-Dallau, Germany, Tel: (49) 6261 9410, Fax: (49) 6261 17741
Asia Pacific: Rockwell Automation, 55 Newton Road, #11-01/02 Revenue House, Singapore 307987, Tel: (65) 351 6723, Fax: (65) 355 1733

Publication 1794-IN095A-EN-P - April 2004

Supersedes Publication 1794-IN028B-EN-P - October 2002, 1794-5.29 - July 1999 and 1794-5.52 - May 1998

ESD Immunity	IEC 61000-4-2: 4kV contact discharges 8kV air discharges
Radiated RF Immunity	IEC 61000-4-3: 10V/m with 1kHz sine-wave 80%AM from 30MHz to 1000MHz 10V/m with 200Hz 50% Pulse 100%AM at 900MHz ±1kV line-earth(CM) on shielded ports
EFT/B Immunity	IEC 61000-4-4: ±2kV at 5kHz on signal ports
Surge Transient Immunity	IEC 61000-4-5: ±1kV line-line(DM) and ±2kV line-earth(CM) on signal ports
Conducted RF Immunity	IEC 61000-4-6: 10Vrms with 1kHz sine-wave 80%AM from 150kHz to 80MHz
Enclosure Type Rating	None (open-style)
Conductors Wire Size Category ¹	12AWG (4mm ²) stranded copper wire rated at 75°C or higher 3/64 inch (1.2mm) insulation maximum
Certifications (when product is marked) ²	UL UL Listed Industrial Control Equipment CSA CSA Certified Process Control Equipment CSA CSA certified for Class I, Division 2, Groups A, B, C and Hazardous locations EEx² European Union 94/9/EEC ATEX Directive, compliant with: EN 50021; Potentially Explosive Atmospheres, Protection "n" (Zone 2) CE² European Union 89/336/EEC EMC Directive, compliant with: EN 61000-6-4; Industrial Emissions EN 50082-2; Industrial Immunity EN 61326; Meas./Control/Lab., Industrial Requirements EN 61000-6-2; Industrial Immunity C-Tick² Australian Radiocommunications Act compliant with AS/NZS CISPR 11, Industrial Emissions

¹ You use this category information for planning conductor routing as described in Allen-Bradley publication 1770-4.1, Industrial Automation Wiring and Grounding Guidelines.

² For the latest up-to-date information, see the Product Certification link at www.ab.com for Declarations of Conformity, Certificates and other certification details. For notification of any additional release notes, refer to www.ab.com/manuals/.

Derating Chart for the 1794-IV16

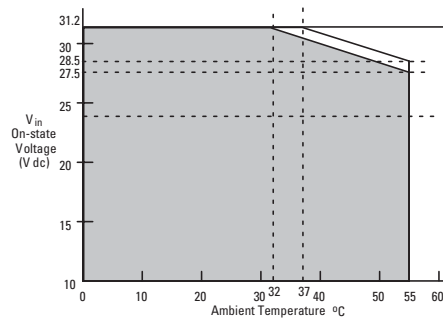

The area within the curve represents the safe operating range for the module under various conditions of user supplied 24V dc supply voltages and ambient temperatures.

□ = Normal mounting safe operating range, (includes □).
■ = Other mounting positions (including inverted horizontal) safe operating range

Voltage	Temperature (max.)		Voltage	Temperature (max.)	
	Normal	Other		Normal	Other
31.2	37	32	29.0	51	45
30.5	41	36	28.5	55	48
30.0	45	39	28.0		51
29.5	48	42	27.5	55	55

PN 957726-40

Copyright © 2004 Rockwell Automation, Inc. All rights reserved. Printed in the U.S.A.