



EXPERION PKS

RELEASE 516

LLMUX2 TC and RTD FTAs User Guide

EPDOC-XX68-en-516A

August 2020

Disclaimer

This document contains Honeywell proprietary information. Information contained herein is to be used solely for the purpose submitted, and no part of this document or its contents shall be reproduced, published, or disclosed to a third party without the express permission of Honeywell International Sàrl.

While this information is presented in good faith and believed to be accurate, Honeywell disclaims the implied warranties of merchantability and fitness for a purpose and makes no express warranties except as may be stated in its written agreement with and for its customer.

In no event is Honeywell liable to anyone for any direct, special, or consequential damages. The information and specifications in this document are subject to change without notice.

Copyright 2020 - Honeywell International Sàrl

Contents	3
Chapter 1 - About this guide	5
1.1 Revision history	5
Chapter 2 - Release Information	6
Chapter 3 - References	7
Chapter 4 - Introduction	8
4.1 Purpose of this document	8
4.1.1 Purpose of the LLMUX2 FTAs	8
4.1.2 Characteristics of the LLMUX2 FTAs	8
4.1.3 LLMUX2 versions	8
4.2 Special Acronyms and Abbreviations	9
4.3 LLMUX2 FTAs Specifications	10
Chapter 5 - Product Information	13
5.1 LLMUX2 TC FTA Overview	13
5.1.1 Parts Included in LLMUX2 TC FTA with local CJR	16
5.2 LLMUX2 RTD FTA Overview	17
5.2.1 Parts Included in LLMUX2 RTD FTA	18
Chapter 6 - Installation Procedures	19
6.1 FTA Installation References	19
6.2 Remote CJR Installation	19
6.2.1 Remote CJR Installation Procedure	20
Chapter 7 - Replacement Procedures	22
7.1 Overview of tasks	22
7.2 Preparation	22
7.2.1 Precautions	22
7.2.2 Tools	22
7.3 FTA Replacement	22
7.3.1 Replacement procedure to replace an LLMUX TC or RTD FTA	23
7.3.2 Reworking 4-pin connector wires for 6-pin LLMUX2 FTA connector	29
Chapter 8 - Service	32
8.1 Troubleshooting the LLMUX2	32
8.1.1 References - Troubleshooting the LLMUX2	32
8.1.2 On-Board Diagnostics	32

8.2 Calibration Procedures	34
8.2.1 LLMUX2 TC Calibration	34
8.2.2 LLMUX2 RTD Calibration	36

ABOUT THIS GUIDE

This guide describes the features, upgraded specifications, and special considerations for installation and maintenance of the LLMUX2 FTAs.

1.1 Revision history

Revision	Date	Description
A	August 2020	Initial release of the document.

RELEASE INFORMATION

Document Name	Document ID	Release Number	Publication Date
LLMUX2 TC and RTD FTAs User Guide EP-DSX315	EPDOC- XX68-en	Release Independent	November 2019

Document Category
Configuration

REFERENCES

The following list identifies all documents that may be sources of reference for material discussed in this publication.

Document Title	
High Performance Process Manager Service	HP13-610
Process Manager/Advanced Process Manager Service	PM13-501
Process Manager I/O Installation	PM20-620
Experion PKS Series C I/O Guide	

- [Purpose of this document](#)
- [Special Acronyms and Abbreviations](#)
- [LLMUX2 FTAs Specifications](#)

4.1 Purpose of this document

Much of the existing documentation for the LLMUX FTAs is applicable to the LLMUX2 FTAs and is not duplicated here. The intent of this document is to describe the differences between the old and new products, including new features, upgraded specifications, and any special considerations or new procedures for installation and maintenance of the LLMUX2 FTAs.

- [Purpose of the LLMUX2 FTAs](#)
- [Characteristics of the LLMUX2 FTAs](#)
- [LLMUX2 versions](#)

4.1.1 Purpose of the LLMUX2 FTAs

The LLMUX2 Field Termination Assemblies (FTAs) replace the LLMUX FTAs, which are no longer being manufactured. The LLMUX2 FTAs are for use with xPM and Experion PMIO. The following are typical scenarios:

- New installations
- Upgrades to add additional capacity
- Replacement of existing LLMUX FTAs, either to replace a failed unit, or to take advantage of the features of the new product

4.1.2 Characteristics of the LLMUX2 FTAs

The new LLMUX2 FTAs have a number of enhancements:

- A separate A/D per channel
- Improved open thermocouple detection within one second
- Improved loop resistance to allow longer thermocouple wiring to the field
- They use solid-state technology, eliminating the use of mercury-wetted relays
- They have on-board diagnostic capability

4.1.3 LLMUX2 versions

The LLMUX2 is available in three versions:

- Thermocouple with local Cold Junction Reference (CJR)
- Thermocouple with remote CJR
- Resistive Thermal Device (RTD)

4.2 Special Acronyms and Abbreviations

The following table lists the special acronyms and abbreviations used in this document.

Table 4.1 Special Acronyms and Abbreviations

Term	Definition
TC	Thermocouple
RTD	Resistance-Temperature-Device
CMV	Common-Mode—Voltage—The voltage common to both input terminals of a device. In a differential amplifier, the unwanted part of the voltage between each input connection point and ground that is added to the voltage of each original signal.
PM	Process Manager
CMRR	Common-Mode Rejection Ratio—The ratio of the common-mode interference voltage at the input of a circuit, to the corresponding interference voltage at the output.
NMRR	Normal-Mode Rejection Ratio—Describes the ability of an instrument to reject a normal (differential) signal. This specification is useful for measurement systems that have filters to eliminate signals at a given frequency or over a range of frequencies.
CJR	Cold-Junction-Reference
IOLP	Input/Output Link Processor
FTA	Field Termination Assembly
DIN	Deutsches Institut für Normung E.V.
JIS	Japanese Industrial Standards
SEER	Steam Electric Evaluation & Recording, Software
ANSI	American National Standards Institute
CSA	Canadian Standards Association
UL	Underwriters Laboratories Inc.
Vac	Voltage, alternating current
Vdc	Voltage, direct current
LLMUX	Low Level Multiplexer

Term	Definition
Pt	Platinum
Ni	Nickel
Cu	Copper

4.3 LLMUX2 FTAs Specifications

The following table lists the detailed specifications for the LLMUX2 TC and LLMUX2 RTD FTAs:

Table 4.2 Specifications

Parameter	Specification
Input channels	16 fully-isolated channel-to-channel, channel-to-PM, and channel-to-power supply common
Input scan rate	1 Second fixed by IOLP
Channel bandwidth	0 to 4.7 Hz (-3 dB)
Nominal input range (TC only)	-20 to +100 millivolts
Maximum normal mode continuous input non-damaging (any thermocouple type configured)	-10 to +10 volts (TC) -1 to +2 Volts @ 100 milliamps (RTD)
Gain error (-20 to +100 millivolt range)	0.050% full scale max
Resolution of reading	
	Type TC
	RTD
	Millivolt
Temperature stability	
	TC, Millivoltage inputs
	RTD inputs
Long term drift	500 ppm
Input impedance	1 megohm at dc (TC only)
CMV with respect to PM common, dc to 60 Hz	+/-250 Vdc or Vac rms
CMRR, 50 or 60 Hz (with 1000 ohms source impedance max.)	120 dB min

Parameter		Specification
Voltage, channel-to-channel, dc to 60 Hz		+/-250 Vdc or Vac rms
Crosstalk, dc to 60 Hz		80 dB (120 dB at 50 and 60 Hz)
NMRR at 60 Hz		60 dB min
NMRR at 50 Hz		60 dB min
Line frequency integration		Fixed selection of 50 Hz or 60 Hz
RTD sensor excitation current		1 milliamp
Cold junction compensation range		-20 to +60 deg C
CJR compensation correction accuracy		+/-0.5 deg C typical
Surge protection (sensor terminals)		IEEE SWC 472-1974
Surge protection (power/serial link with cable adapter option)		IEEE SWC 472-1974
Maximum cable distance IOLP to FTA using cable adapter		1000 feet 16 gauge wire, two twisted pair per FTA
Supported types (RTD)		
	Pt: 100 ohm DIN 4376	-180 to +800 deg C
	Pt: 100 ohm JIS C-1604	-180 to +650 deg C
	Ni: 120 ohm ED #7	-45 to +315 deg C
	Cu: 10 ohm SEER	-20 to +250 deg C
Supported thermocouple types		
	ANSI specification J	-200 to +1200 deg C
	ANSI specification K	-100 to +1370 deg C
	ANSI specification E	-200 to +1000 deg C
	ANSI specification T	-230 to +400 deg C
	ANSI specification B	+100 to +1820 deg C
	ANSI specification S	0 to +1700 deg C

Parameter		Specification
	ANSI specification R	0 to +1700 deg C
	JAPAN TYPE R'	0 to +1770 deg C
Supported millivolt types		-20 to +100 millivolts
Power dissipation		2.25 watts max
Thermal dissipation		7.68 Btu per hour max
Environmental conditions		
	Operational temperature	0 to 50 deg C (32 to 122 deg F)
	Storage temperature	-40 to 80 deg C (-40 to 185 deg F)
	Relative Humidity	10 to 90% non-condensing (max operating temperature is 40 deg C)
	Shock operating	30 g peak acceleration 11 +/-1 millisecond pulse width
	Shock non-operating	50 g peak acceleration 11 +/-1 millisecond pulse width
	Vibration	0.5 g at 10-60 Hz or 0.1 inches displacement
External dc power		
	Supply voltage	24 Vdc nominal
	Voltage range	15 to 30 Vdc
	Supply current	160 milliamps at 15 Vdc
Agency certifications (when product or packaging is marked)		
		CSA certified
		CSA Class 1, Division 2
		Groups A, B, C, D certified
		UL listed and CE marked for all applicable directives
Major dimensions		2.5 D x 4.9 W x 12.1 L (inches) 63.5 D x 124.46 W x 307.34 L (millimeters)

- [LLMUX2 TC FTA Overview](#)
- [LLMUX2 RTD FTA Overview](#)

5.1 LLMUX2 TC FTA Overview

The LLMUX2 TC FTA version shown in Figure 2-1 has increased reliability and uses solid-state components instead of mercury relays.

Figure 5.1 LLMUX2 TC FTA with Cover



The model numbers and part numbers of the LLMUX2 TC FTA are listed in Table 2-1.

Table 5.1 LLMUX2 TC FTA Version

Model Number	Description	Part Number
MC-TAMT04	LLMUX2 TC FTA with Local CJR Compression Terminals, Single IOP Interface, Conformally Coated, CE Compliant	51305890-175 (FTA)
MC-TAMT14	LLMUX2 TC FTA with Remote CJR Compression Terminals, Single IOP	51305890-175 (FTA) 51305902-175 (Remote)

Model Number	Description	Part Number
	Interface, Conformally Coated, CE Compliant	CJR) 51190771-404 (4-Pin Connector)

The LLMUX2 TC FTA is CE-compliant, conformally coated, and is a direct replacement for the LLMUX TC FTAs listed in Table 2-2. As shown in Table 2-2, the LLMUX2 TC FTA replaces both CE compliant and non-CE compliant versions.

Table 5.2 LLMUX TC FTA Models Replaced by LLMUX2 TC FTA

Model Number	Description	Non-CE Compliant	CE Compliant
		Part Number	Part Number
MU-TAMT02	LLMUX TC FTA with Local CJR, Compression Terminals, Single IOP Interface	51401491-100	N/A
MC-TAMT02	LLMUX TC FTA with Local CJR Compression Terminals, Single IOP Interface Conformally Coated	51401491-150	N/A
MU-TAMT03	LLMUX TC FTA with Local CJR, Compression Terminals, Single IOP Interface	N/A	51309223-125
MC-TAMT03	LLMUX TC FTA with Local CJR, Compression Terminals, Single IOP Interface, Conformally Coated	N/A	51309223-175
MU-TAMT12	LLMUX TC FTA with Remote CJR, Compression Terminals, Single IOP Interface	51401573-100 51304589-100	N/A
MC-TAMT12	LLMUX TC FTA with Remote CJR Compression Terminals, Single IOP Interface Conformally Coated	51401573-150 51304589-150	N/A
MU-TAMT13	LLMUX TC FTA with Remote CJR, Compression Terminals, Single IOP Interface	N/A	51309213-125 51304589-

Model Number	Description	Non-CE Compliant	CE Compliant
		Part Number	Part Number
			100
MC-TAMT13	LLMUX TC FTA with Remote CJR, Compression Terminals, Single IOP Interface, Conformally Coated	N/A	51309213-175 51304589-150

- [Parts Included in LLMUX2 TC FTA with local CJR](#)

5.1.1 Parts Included in LLMUX2 TC FTA with local CJR

Table 2-3 lists the parts that are shipped when the LLMUX2 TC FTA with local CJR (Model Number MC-TAMT04) is ordered from Honeywell.

Table 5.3 Parts for Model MC-TAMT04 LLMUX2 TC FTA w/local CJR

Part Number	Description	Quantity
51305890-175	LLMUX2 TC FTA Model MC-TAMT04	1
51190771-508	8- Pin Connector with Compression Terminals	4
51195776-100	6-Pin Connector with Compression Terminals	1

Table 2-4 lists the parts that are shipped when the LLMUX2 TC FTA with remote CJR (Model Number MC-TAMT14) is ordered from Honeywell.

Table 5.4 Parts for Model MC-TAMT14 LLMUX2 TC FTA w/remote CJR

Part Number	Description	Quantity
51305890-175	LLMUX2 TC FTA Model MC-TAMT04	1
51190771-508	8-Pin Connector with Compression Terminals	4
51190776-100	6-Pin Connector with Compression Terminals	1
51305902-175	Remote CJR Assembly	1
51190771-404	4-Pin connector with Compression Terminals	2

ATTENTION

- Note that the 51190771-508, 51195776-100, and 51190771-404 connectors have been supplied with the LLMUX2 TC FTA so that the connectors could be used in a new installation when necessary.
- When using the remote CJR model, the cable that connects the remote CJR to the FTA must be ordered separately. This cable is Honeywell model number MU-KRCJ00 (Belden Type 83653) and has a maximum length of 50 meters (164 feet).

5.2 LLMUX2 RTD FTA Overview

The LLMUX2 RTD FTA version shown in Figure 2-2 has increased reliability and uses solid-state relays instead of mercury relays.

Figure 5.2 LLMUX2 RTD FTA with Cover

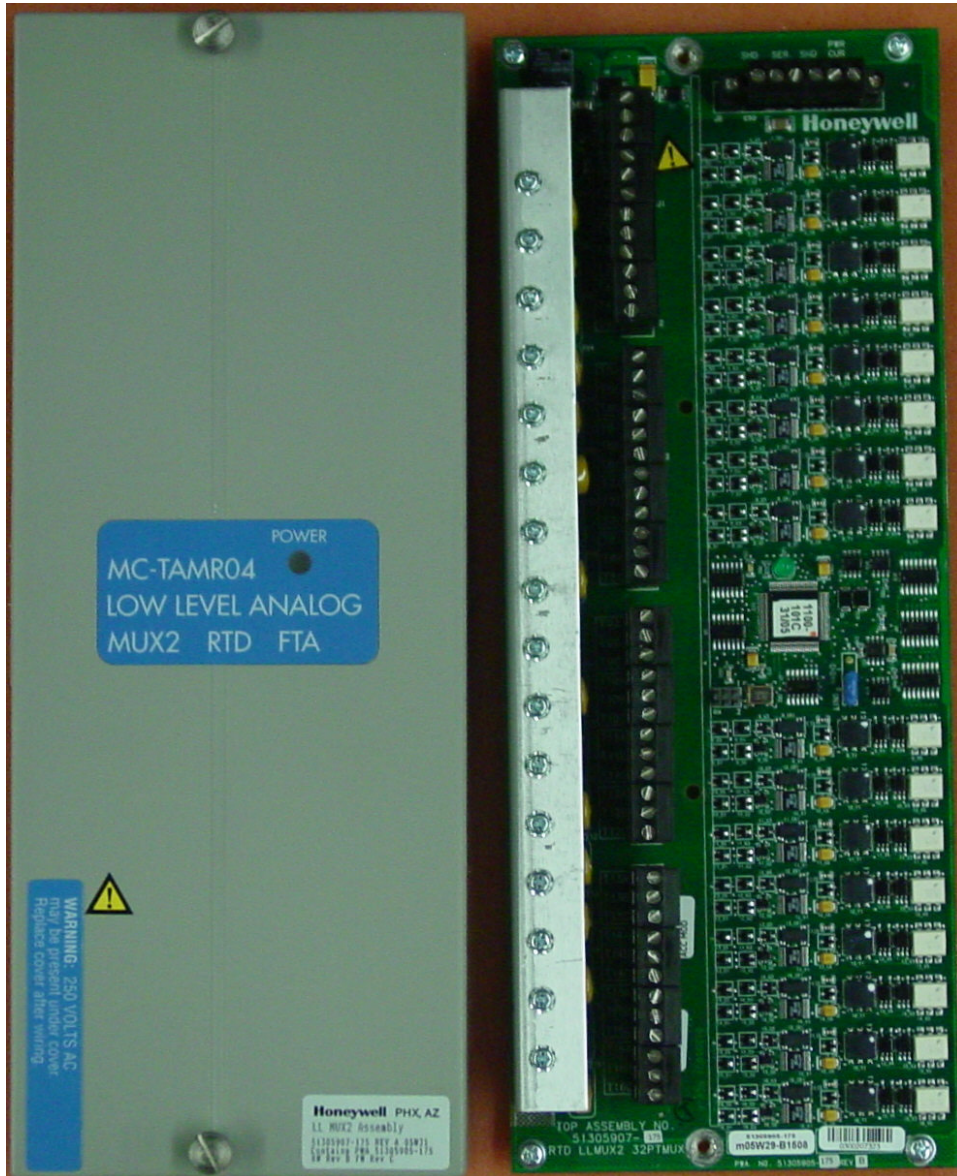

The model number and part number of the LLMUX2 RTD FTA is listed in Table 2-5.

Table 5.5 LLMUX2 RTD FTA Version

Model Number	Description	Part Number
MC-TAMR04	LLMUX2 RTD FTA with Compression Terminals, Single IOP Interface, Conformally Coated, CE Compliant	51305907-175

The LLMUX2 RTD FTA is CE-compliant, conformally coated, and is a direct replacement for any of the LLMUX RTD FTAs listed in Table 2-6. As shown in Table 2-6, the LLMUX2 RTD FTA replaces both the CE compliant and non-CE compliant versions.

Table 5.6 LLMUX RTD FTA Models Replaced by LLMUX2 RTD FTA

Model Number	Description	Non-CE Compliant	CE Compliant
		Part Number	Part Number
MU-TAMR02	LLMUX RTD FTA with Compression Terminals, Single IOP Interface	51304477-100	N/A
MC-TAMR02	LLMUX RTD FTA with Compression Terminals, Single IOP Interface, Conformally Coated	51304477-150	N/A
MU-TAMR03	LLMUX RTD FTA, Compression Terminals, Single IOP Interface	N/A	51309218-125
MC-TAMR03	LLMUX RTD FTA, Compression Terminals, Single IOP Interface, Conformally Coated	N/A	51309218-175

- [Parts Included in LLMUX2 RTD FTA](#)

5.2.1 Parts Included in LLMUX2 RTD FTA

The Table 2-7 lists the parts that are shipped when LLMUX2 RTD FTA part number 51305907-175 is ordered from Honeywell.

Table 5.7 Parts for LLMUX2 RTD FTA

Part Number	Description	Quantity
51305907-175	LLMUX2 RTD FTA Model MC-TAMR04	1
51190771-403	3-Pin Connector with Compression Terminals	16
51195776-100	6-Pin Connector with Compression Terminals	1

ATTENTION

Note that the 51190771-403 connectors and the 51195776-100 connectors have been supplied with the LLMUX2 RTD FTA so that the connectors could be used in a new installation when necessary.

INSTALLATION PROCEDURES

- [FTA Installation References](#)
- [Remote CJR Installation](#)

6.1 FTA Installation References

The installation procedures that are referenced in this section include the installation of channels and the mounting of the FTAs if you are adding additional capacity. These installation procedures for the LLMUX2 TC and RTD FTAs are the same as for the earlier LLMUX types and are not repeated here. Refer to the *Process Manager I/O Installation* manual for detailed information. That manual also includes information about FTA mounting channels in the event that your installation requires additional mounting channels.

For Experion PMIO installations, refer to the *Experion PKS Series C I/O Guide*.

For information about installing a remote CJR (part of model MC-TAMT14), refer to section 3.2 below.

Information in this manual in Section 4, 'Replacement Procedures,' may be useful in performing your installation. In fact, if you are experienced with FTA installation, the information and figures in this section may be all that you require. The installation procedure for an LLMUX2 is basically the same as the procedure for replacement of an LLMUX with an LLMUX2 except that you do not remove an existing unit.

6.2 Remote CJR Installation

The acronym 'CJR' stands for Cold Junction Reference. A CJR is required when thermocouples are used to sense temperature. The thermocouple provides a voltage that is a function of the difference in temperature between the probe tip (hot junction) and the other end of the thermocouple wires (at the cold junction reference). The microprocessor in the FTA converts this relative temperature to absolute temperature using the differential reading of the thermocouple and the absolute temperature of the CJR.

If the thermocouples are terminated directly on the FTA, a 'local' (on the FTA) CJR is used. However, in some instances the thermocouples may be terminated at a remote 'marshalling' panel and then connected to the LLMUX2 with copper wire. In this case, the CJR should be located at the point where the thermocouples 'go to copper' in order to ensure accuracy of measurement. This is when the use of the Remote CJR option is appropriate.

Note that the same FTA (51305890-175) is used regardless of whether you order the LLMUX2 TC with local CJR (model MC-TAMT04) or the LLMUX2 TC with Remote CJR (model MC-TAMT14). A jumper on the FTA assembly selects whether to use the local (on-board) CJR or the Remote CJR. The model MC-TAMT14 includes the extra components required to provide the Remote CJR implementation.

- [Remote CJR Installation Procedure](#)

6.2.1 Remote CJR Installation Procedure

ATTENTION

The Remote CJR unit (51305902-175) supplied with the new LLMUX2 FTA model MC-TAMT14 is *NOT* the same as the version used with the older LLMUX FTAs. You must use the newer version of the Remote CJR that is shown in Figure 3-1 when you are installing a new MC-TAMT14 FTA or when you are replacing an older model FTA with a new MC-TAMT14 FTA.

Figure 3-1 the Remote CJR assembly. This assembly should be mounted at the patch, or marshalling, panel where the thermocouples are terminated and connected to the copper wire cables that transmit the thermocouple voltages to the LLMUX2 TC FTA.

ATTENTION

The new 51305902 Remote CJR Assembly has components on the underside of the assembly (unlike the older 51304589 Remote CJR Assembly). If the 51305902 Remote CJR Assembly is to be mounted on a flat surface, it may be necessary to use the provided standoffs (51200520-260) to mount the assembly.

Figure 6.1 Remote CJR

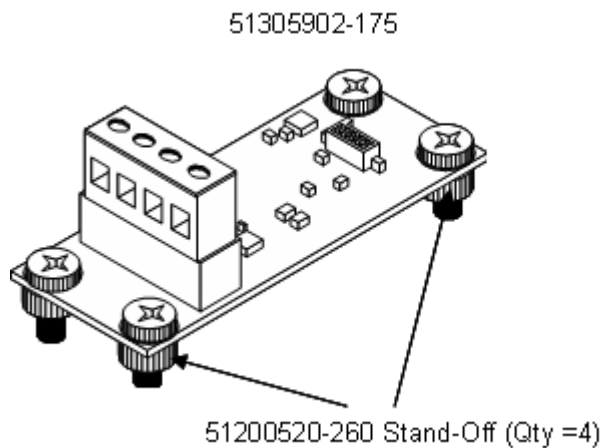

below shows in pictorial form the connection of the Remote CJR to the LLMUX2 TC FTA.

Figure 6.2 Remote CJR Cabled to FTA

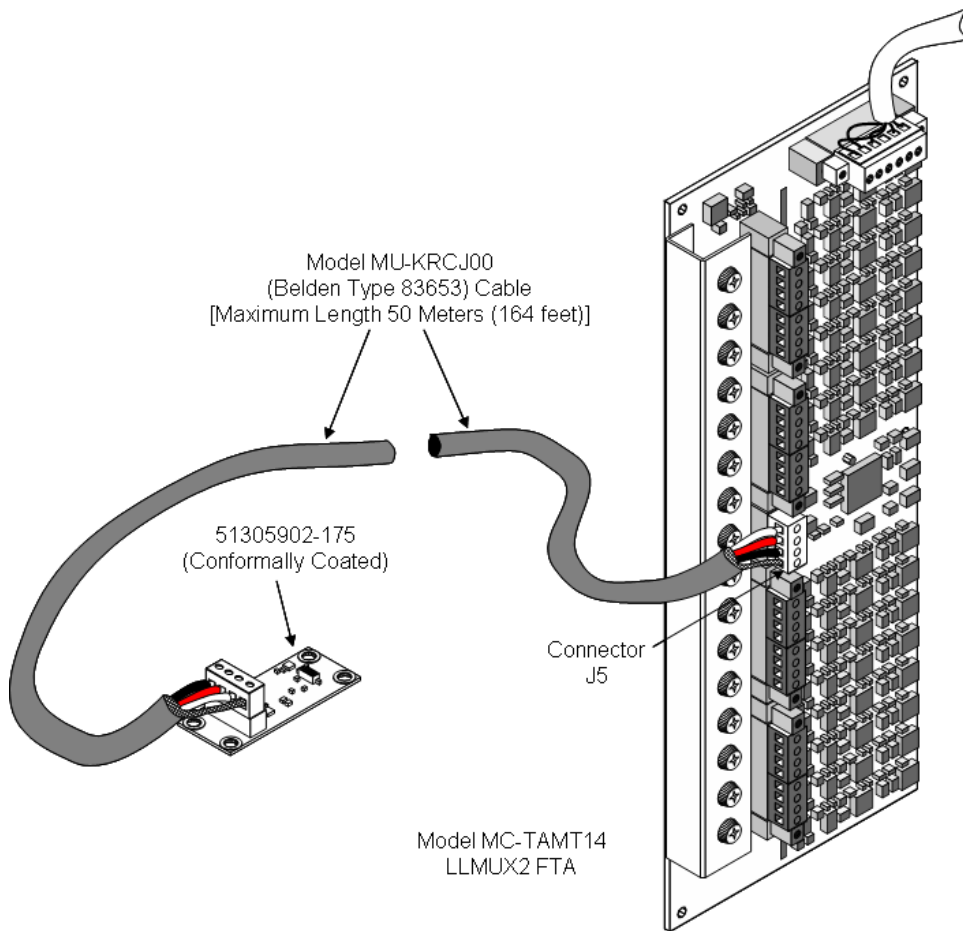
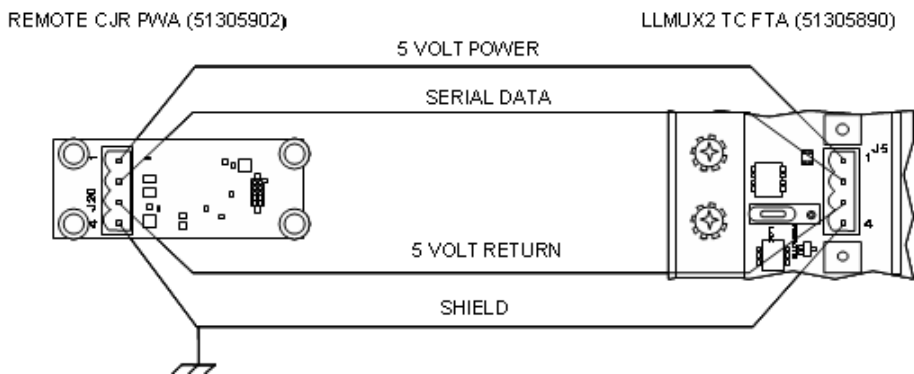

Figure 3-2 below shows the cable interconnections between the Remote CJR and the LLMUX2 TC FTA.

Figure 6.3 Remote CJR Wiring Diagram



REPLACEMENT PROCEDURES

- [Overview of tasks](#)
- [Preparation](#)
- [FTA Replacement](#)

7.1 Overview of tasks

This section contains a step-by-step procedure for replacing LLMUX TC and RTD FTAs with the LLMUX2 TC and RTD FTAs, respectively. The same procedure is to be used regardless of whether you are replacing a TC FTA or an RTD FTA.

7.2 Preparation

- [Precautions](#)
- [Tools](#)

7.2.1 Precautions

- Observe all safety precautions at your plant site about handling process wiring and making process connections.
- Before you disconnect any cable from the LLMUX FTA, ensure that the cable has wire markers with the origin and destination connections properly labeled.

7.2.2 Tools

You will need the following tools for the procedures in this document:

- Small-size Phillips-head screwdriver
- Medium-size Phillips-head screwdriver
- Medium-size flat-blade screwdriver

7.3 FTA Replacement

ATTENTION

Before performing the FTA replacement procedure, it may be necessary to back-up the process loops that may be affected by the FTA replacement procedure.

WARNING

Risk of electrical shock: 250 VOLTS AC may be present under the FTA cover from the field wiring. Ensure that you replace the FTA cover after you connect the FTA wiring.

- [Replacement procedure to replace an LLMUX TC or RTD FTA](#)
- [Reworking 4-pin connector wires for 6-pin LLMUX2 FTA connector](#)

7.3.1 Replacement procedure to replace an LLMUX TC or RTD FTA

Use the procedure in Table 4-1 to replace an LLMUX TC or RTD FTA with an LLMUX2 TC or FTA, respectively.

1. Call-up your Operations Center and ask the process operator to record the PV value of each of the up-to-16 process variables of the LLMUX FTA that is to be replaced so that you can compare the values against the values recorded after the new LLMUX2 FTA is installed in step 18.
2. If a second LLMUX is connected to the same Power Adapter, ensure that the process operator also records the PV values of the second LLMUX.
3. Using a flat-blade screwdriver, loosen two retaining screws on the FTA cover and remove cover from FTA.
4. Unplug the 50-pin connector (J1) at the Power Adapter to disconnect the LLMUX IOP from the associated Power Adapter. Refer to Figures 4-1, 4-2, or 4-3.
This is a *recommended* step. However, be aware that this will take both of the FTAs on the Power Adapter off line.
5. Using a small screwdriver, loosen the two screws that hold the 6-pin or 4-pin connector to connector J6 at the top of the LLMUX FTA. Unplug the connector. Refer to Figures 4-1, 4-2, or 4-3.
6. For the TC FTA:
Using a small screwdriver, loosen two screws for each of the following 8-pin connectors located on the left side of the FTA: J1, J2, J3, and J4. Unplug the connectors. It is not necessary to unscrew the field wiring if compression terminals are used. Refer to Figure 4-4.
For the RTD FTA:
For connectors T1-T16 (one connector for each RTD input) located on the left side of the FTA, unplug the connectors from J1-J4. Refer to Figure 4-5.
7. This step is only required if you are replacing an FTA that has a remote CJR.
8. Using a small screwdriver, loosen two screws at 4-pin connector J5 and unplug the connector. Refer to Figure 4-4.
9. Using a medium-size Phillips-head screwdriver, loosen the four screws that hold the FTA in the FTA mounting channel until the FTA can be removed. The standoffs will retain the screws with the board. Carefully remove the FTA.

10. Compare the replacement LLMUX2 FTA with the removed LLMUX FTA. Be sure the jumpers are properly positioned on the replacement FTA. Note the position of the address jumper labeled "UNIT," which can be configured for '0' or '1.' Configure the replacement FTA to the same UNIT address as the old FTA. If the replacement FTA is a TC, note the CJR jumper labeled 'JMP2.' This jumper has two choices, labeled 'LOC' (for local CJR), and 'REM' (for remote CJR). Be sure this jumper is in the proper position on the replacement FTA.
11. Install the replacement FTA with the screws that were loosened in step 8 and are still retained with the FTA by the standoff mounts. Rotate the screws in the counterclockwise direction until they fall into the original threads, then tighten them in the clockwise direction.
12. This step is only required if you are replacing an FTA that has a remote CJR.
The existing remote CJR assembly (51304589) must be replaced with a new remote CJR assembly (51305902). Use the existing cable and connectors. Reconnect the 4-pin connector to J5 and tighten the screws. Connect the other end of the cable to the new remote CJR. Refer to Figures 3-1, 3-2, and 3-3 in Section 3.2.2 'Remote CJR Installation Procedure.'
13. For the TC FTA:
Reconnect 8-pin connectors J1, J2, J3, and J4 and tighten the screws. Refer to Figure 4-4.
For the RTD FTA:
Reconnect the 16 3-pin connectors to positions T1-T16 on J1-J4 and tighten the screws. Refer to Figure 4-5.
14. Reconnect the 6-pin connector to J6 at the top of the LLMUX2 FTA. Refer to Figures 4-1, 4-2, or 4-3. If your installation has a 4-pin connector instead of the 6-pin connector, you have to rework the wires as described in Section 4.3.2, and then return to step 14 of this procedure.
15. Connect the 50-pin connector at the Power Adapter to connect the LLMUX IOP to the associated Power Adapter. Refer to Figures 3-1, 3-2, or 3-3.
16. Mount the new cover on the FTA and use a flat-blade screwdriver to tighten the two retaining screws on the FTA cover. If the old cover has custom labels already in place, you can use it instead of the new cover.
17. If desired, attach a new label to the new FTA cover to indicate the wire numbers of the wires that are connected to the FTA, unless you used the old cover as indicated in the previous step.
18. If necessary, reload the LLMUX IOP database.

- Record the value of each PV to ensure that the value is the same as that recorded in steps 1 and 2.

Figure 7.1 FTA Connections to Non-CE Compliant Power Adapter (LLMUX2 Mounted in Same Cabinet (Internal) as Power Adapter)

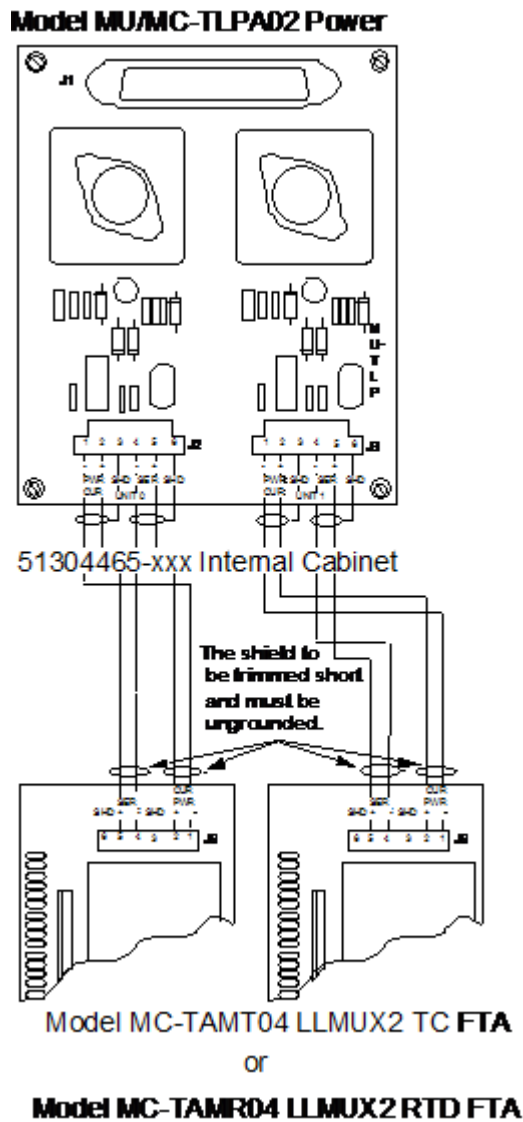

Figure 7.2 FTA Connections to Non-CE Compliant Power Adapter (LLMUX2 Mounted in Cabinet External from Power Adapter)

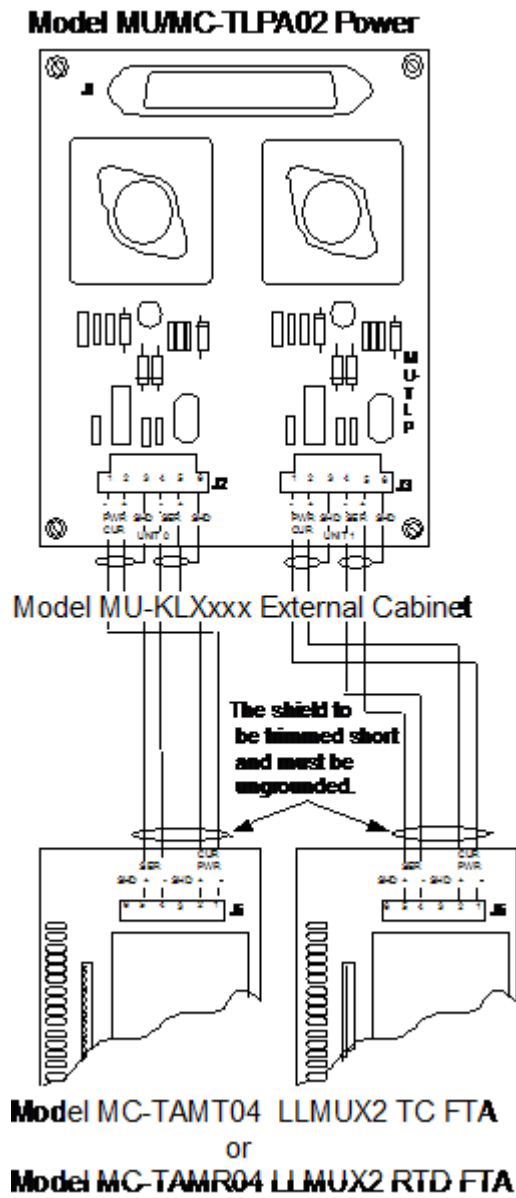

Figure 7.3 FTA Connections to CE Compliant Power Adapter (LLMUX2 Mounted in Same Cabinet Internal) as Power Adapter)

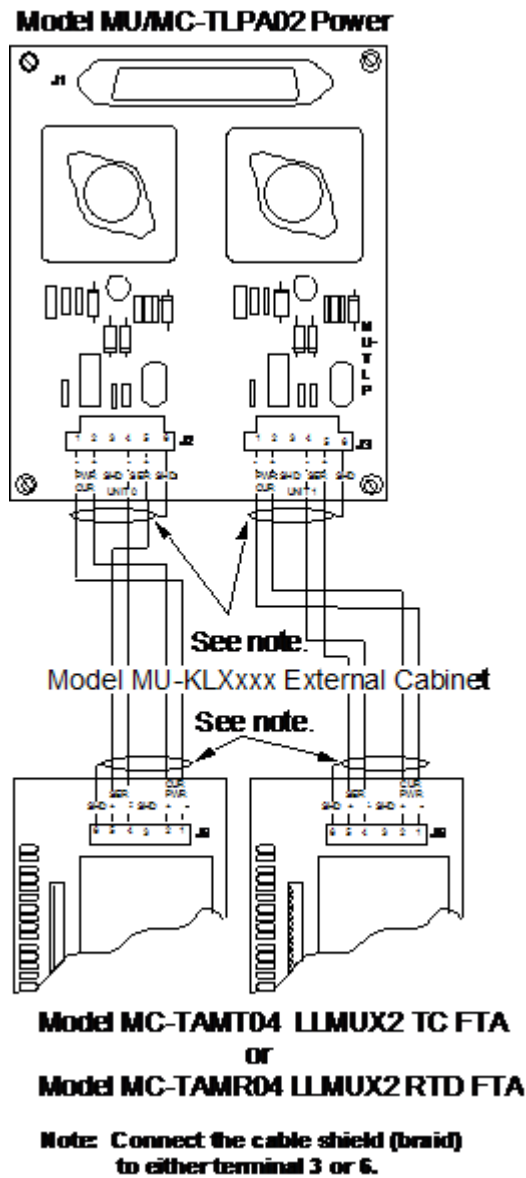
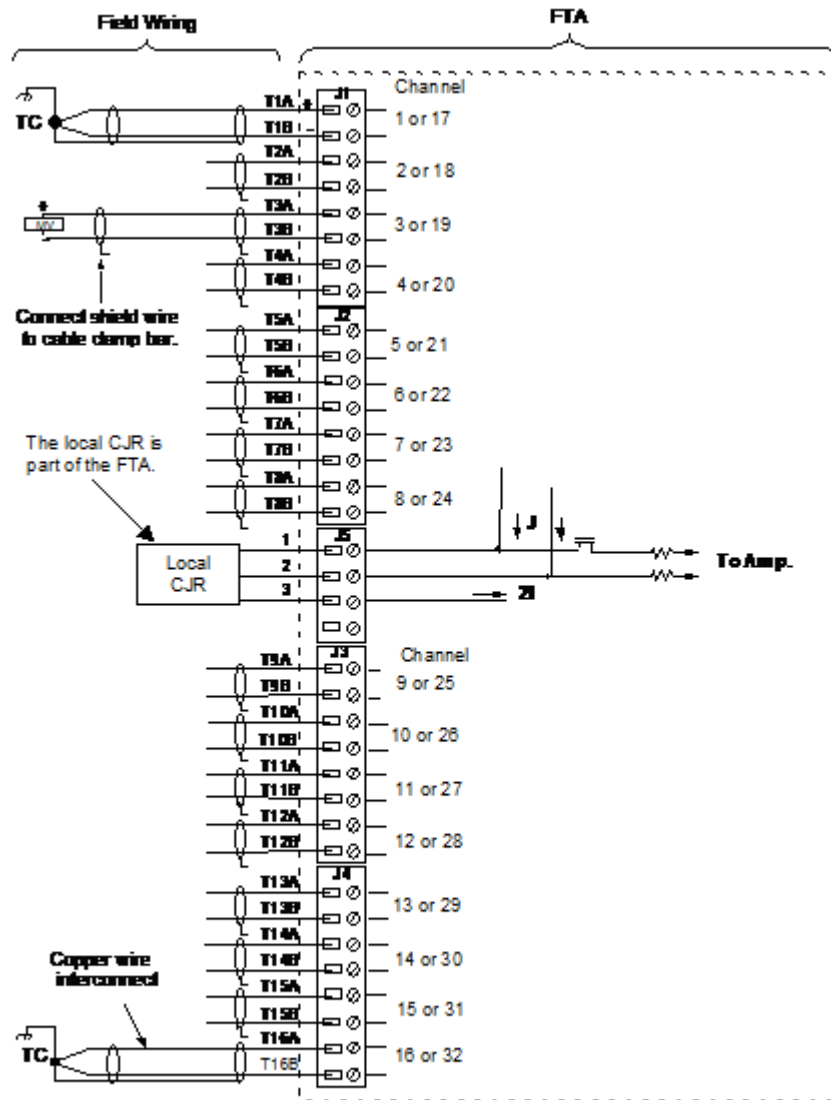
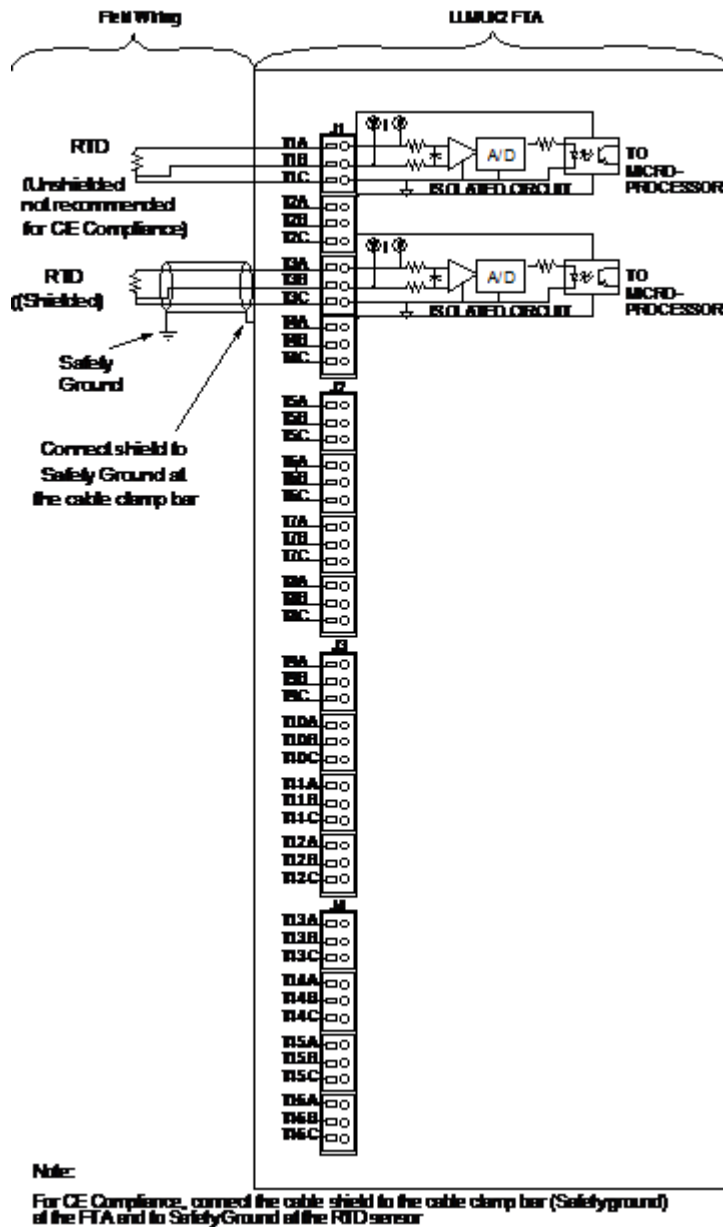

Figure 7.4 Field Wiring Connections to LLMUX2 TC FTA



Connect the shield to ground of the sensor. If the shield cannot be grounded at the sensor, connect the shield to ground at the FTA and allow the shield to float at the sensor. Ground is defined as Safety Ground for CE Compliance.

Figure 7.5 Field Wiring Connections to LLMUX2 RTD FTA



7.3.2 Reworking 4-pin connector wires for 6-pin LLMUX2 FTA connector

If your current non-CE FTA has a 4-pin connector at the top of the FTA, the wires must be reworked for the 6-pin connector of the LLMUX2 FTA (Figure 4-1). A new 6-pin connector is provided with the LLMUX2 FTA.

Basically, the procedure for reworking the wires consists of removing the four wires from the current non-CE FTA 4-pin connector and inserting them into the supplied new 6-pin connector in accordance with the wire/terminal designations listed in Tables 4-2 and 4-3.

If you have a non-CE FTA that has a 6-pin connector, you do not have to rework the wires in the connector. You would connect the 6-pin connector as shown in Figures 4-1 and 4-6.

Figure 7.6 4-Pin and 6-Pin Connectors

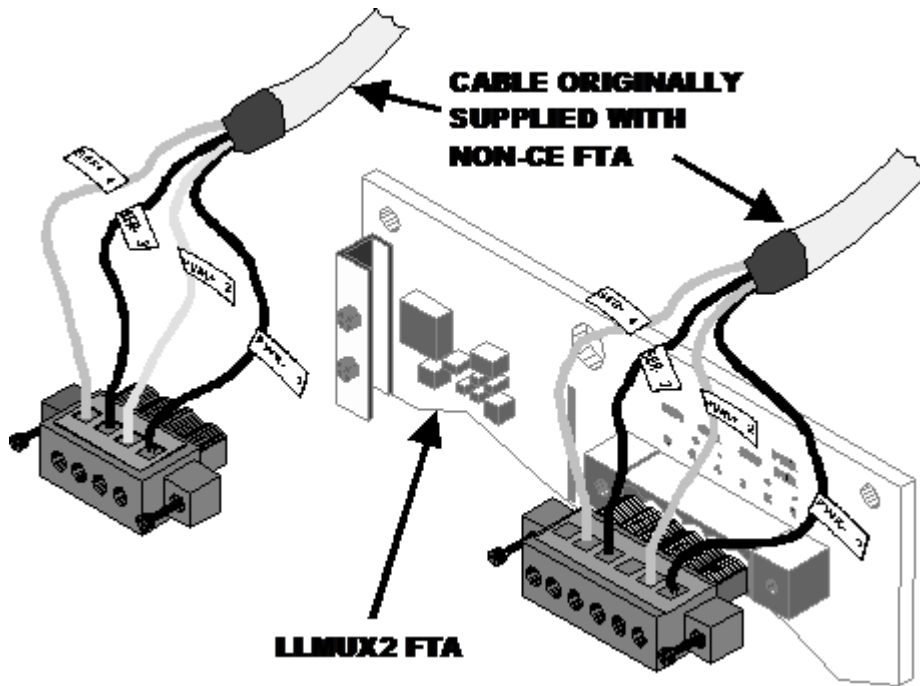

The connections to the 6-pin connector are identical for LLMUX2 FTAs regardless if the FTA is mounted in the same cabinet as the Power Adapter, or in a different cabinet. The only difference is in the wire designators that are attached to the wires as listed in Tables 4-2 and 4-3.

After you connect the wires to the new 6-pin connector, return to step 14 of the procedure in Table 4-1.

Table 7.1 Connections when Power Adapter and LLMUX2 FTA are in same cabinet

Connections at Power Adapter		Connections at 4-Pin Connector of Non-CE LLMUX FTA		Connections at 6-Pin Connector (J6) of LLMUX2 FTA	
Power Adapter Terminals	Cable Wire Designations	Cable Wire Designations	LLMUX FTA Terminals	Cable Wire Designations	LLMUX2 FTA Terminals
1 CUR PWR -	1 - PWR	1 CURPWR -	1 CUR PWR -	1 CURPWR -	1 CUR PWR -
2 CUR PWR +	2 + PWR	2 CURPWR +	2 CUR PWR +	2 CURPWR +	2 CUR PWR+
3 SHD	3 SHD				3 Not used
4 SER -	4 - SER	3 SERCOM -	4 SER -	3 SERCOM -	4 SER -
5 SER +	5 + SER	4 SERCOM +	5 SER +	4 SERCOM +	5 SER +

Connections at Power Adapter		Connections at 4-Pin Connector of Non-CE LLMUX FTA		Connections at 6-Pin Connector (J6) of LLMUX2 FTA	
Power Adapter Terminals	Cable Wire Designations	Cable Wire Designations	LLMUX FTA Terminals	Cable Wire Designations	LLMUX2 FTA Terminals
6 SHD	6 SHD				6 Not used

Table 7.2 Connections when LLMUX2 FTA is in a remote cabinet

Connections at Power Adapter (J2 or J3)		Connections at 4-Pin Connector of Non-CE LLMUX FTA		Connections at 6-Pin Connector (J6) of LLMUX2 FTA	
Power Adapter Terminals	Cable Wire Designations	Cable Wire Designations	LLMUX FTA Terminals	Cable Wire Designations	LLMUX2 FTA Terminals
1 CUR PWR -	1 BLK1	1 BLK1	1 CUR PWR -	1 BLK1	1 CUR PWR -
2 CUR PWR +	2 RED1	2 RED1	2 CUR PWR +	2 RED1	2 CUR PWR+
3 SHD	3 SHD1				3 Not Used
4 SER -	4 BLK2	3 BLK2	3 SER COM -	3 BLK2	4 SER -
5 SER +	5 RED2	4 RED2	4 SER COM +	4 RED2	5 SER +
6 SHD	6 SHD2				6 Not used

- [Troubleshooting the LLMUX2](#)
- [Calibration Procedures](#)

8.1 Troubleshooting the LLMUX2

- [References - Troubleshooting the LLMUX2](#)
- [On-Board Diagnostics](#)

8.1.1 References - Troubleshooting the LLMUX2

The procedures for troubleshooting and identifying a failed LLMUX2 are the same as for the previous LLMUX units and are not repeated here. These procedures involve the use of system status displays and logs. For information on these procedures, refer to the *Process Manager/Advanced Process Manager Service* or the *High-Performance Process Manager Service* manual. In addition, on-board diagnostics are available on LLMUX2 FTAs that can provide additional diagnostic information. See section 5.1.2 below.

After a failed LLMUX2 FTA is identified, the service procedure is to replace the unit. The FTAs are not serviceable in the field.

8.1.2 On-Board Diagnostics

LLMUX2 FTAs have on-board diagnostic capability that was not available on previous LLMUX FTAs. These diagnostics use a red and a yellow LED to communicate diagnostic information to the user. These LEDs are in addition to the green LED that indicates power on. (The red and yellow LEDs can only be seen with the FTA cover off.) The diagnostics run at startup (power on) and certain tasks run as background processes during normal operation.

Figure 5-1 shows the location of the red, yellow, and green LEDs on the LLMUX2 TC PWA.

Figure 5-2 shows the location of the red, yellow, and green LEDs on the LLMUX2 RTD PWA.

Figure 8.1 Location of Diagnostic LEDs on the LLMUX2 TC FTA

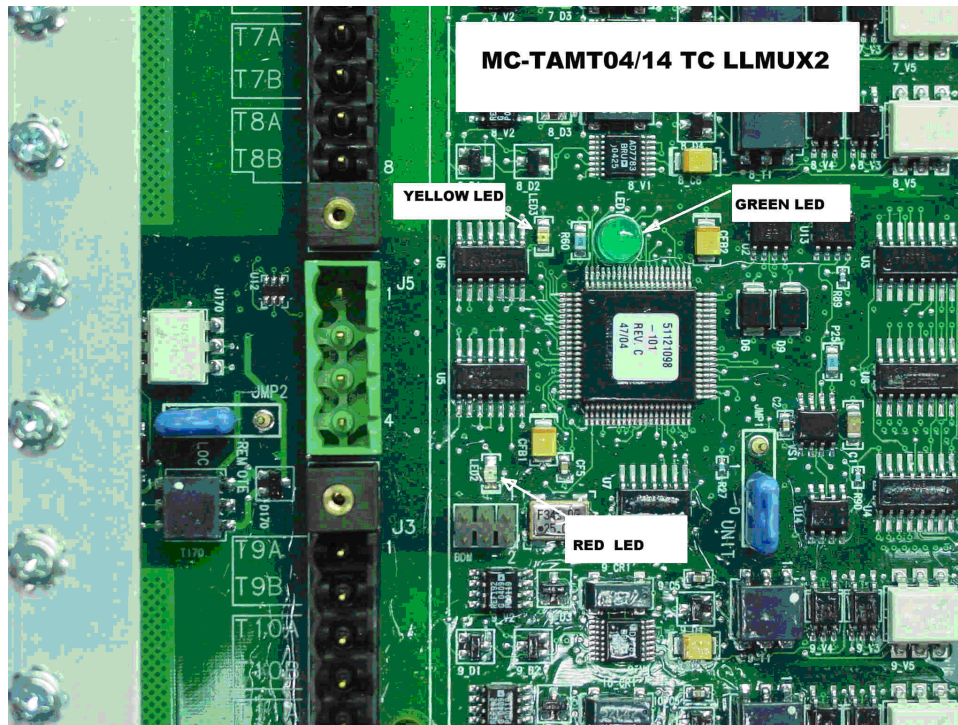
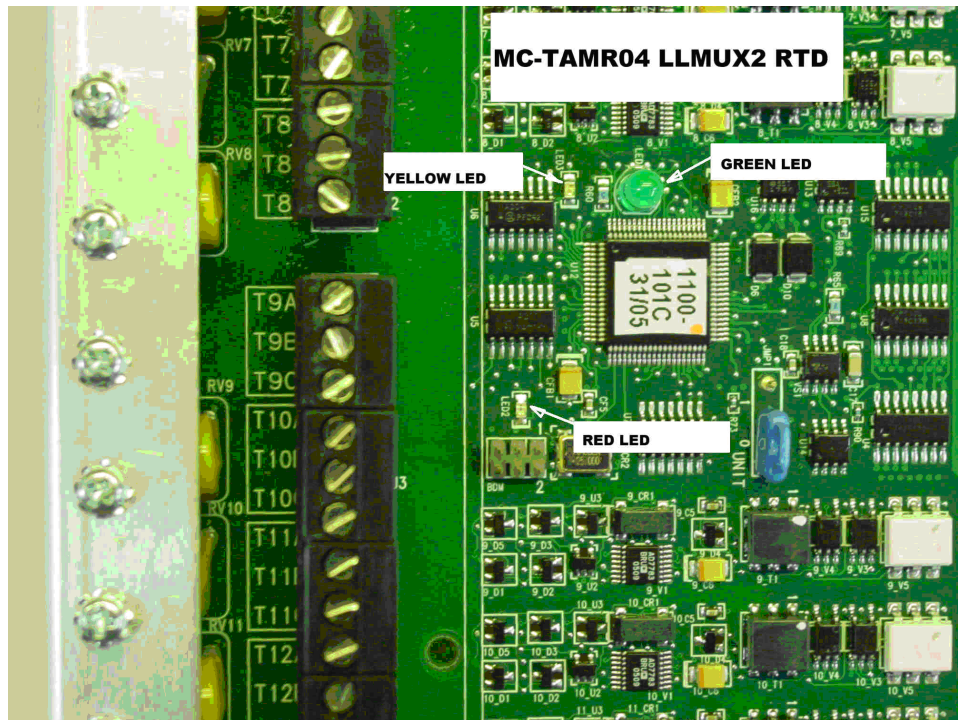

Figure 8.2 Location of Diagnostic LEDs on the LLMUX2 RTD FTA



The following table indicates the information conveyed by the LEDs.

Table 8.1 FTA On-Board LEDs

LED	State	Description
Green	On	FTA Power On
	Off	FTA Power Off
Red	On	Error condition. Some of the possible causes are: <ul style="list-style-type: none"> • Initialization in process • Checksum error - initial or background • Firmware and FTA mismatch • Remote CJR not communicating with FTA • Millivolt Calibration in process Light will be blinking (see 5.1.2)
	Off	Normal state (no errors)
Yellow	On	Normal state (no errors). Communication with IOLP is working properly. Open Thermocouple Detect Calibration is in process. Light will be blinking (see 5.1.2)
	Off	<ul style="list-style-type: none"> • Error condition. The most likely cause is a communication failure between the IOP and the FTA. Other error conditions are possible, however.

8.2 Calibration Procedures

- [LLMUX2 TC Calibration](#)
- [LLMUX2 RTD Calibration](#)

8.2.1 LLMUX2 TC Calibration

There are no adjustments on the LLMUX2 TC subsystem for calibration purposes. Calibration in the field is not recommended. However, if you decide to perform calibration, the setup for the LLMUX2 TC is not the same as it was for the older LLMUX TC FTAs. The older LLMUX TC FTAs included only one A/D converter, whereas the LLMUX2 includes 16 A/D converters (one per channel). Therefore, the calibration setup for the LLMUX2 TC is different, and more complex, than the original LLMUX calibration setup. In the new setup, a precision 100 millivolt (0.01 %) voltage source must be connected to *each* channel through a 1270 (1 %) ohm resistor. Figure 5-3 shows the connections required to perform a calibration operation. Figure 5-4 shows a pictorial diagram of the calibration setup.

After the setup is completed, the calibration is initiated from the Low Level Multiplexer IOP Detail Status Display. The procedure is covered in the *High-Performance Process Manager Service* and the *Process Manager/Advanced Process Manager Service* manuals and is not repeated here. The procedure covered in those manuals is the same for the LLMUX2 with the exception that the setup is different, as covered in this document.

The calibration process involves the FTA reading the precision source and then storing this data in non-volatile EEPROM on the FTA. Both the millivolt and the open thermocouple detection functions are calibrated by this operation and no additional steps are required.

The red LED on the LLMUX2 FTA will be blinking during the millivolt calibration process and the yellow led will be blinking during the open thermocouple calibration process. The blinking is a result of the FTA cycling through the 16 channels, calibrating them independently and sequentially.

Figure 8.3 Connection Diagram for LLMUX2 TC Calibration

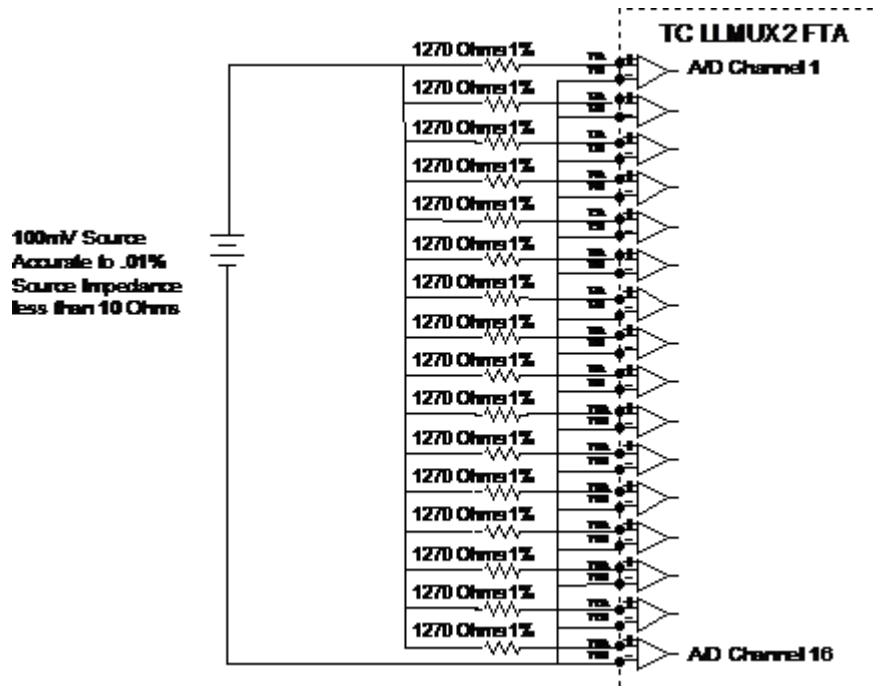
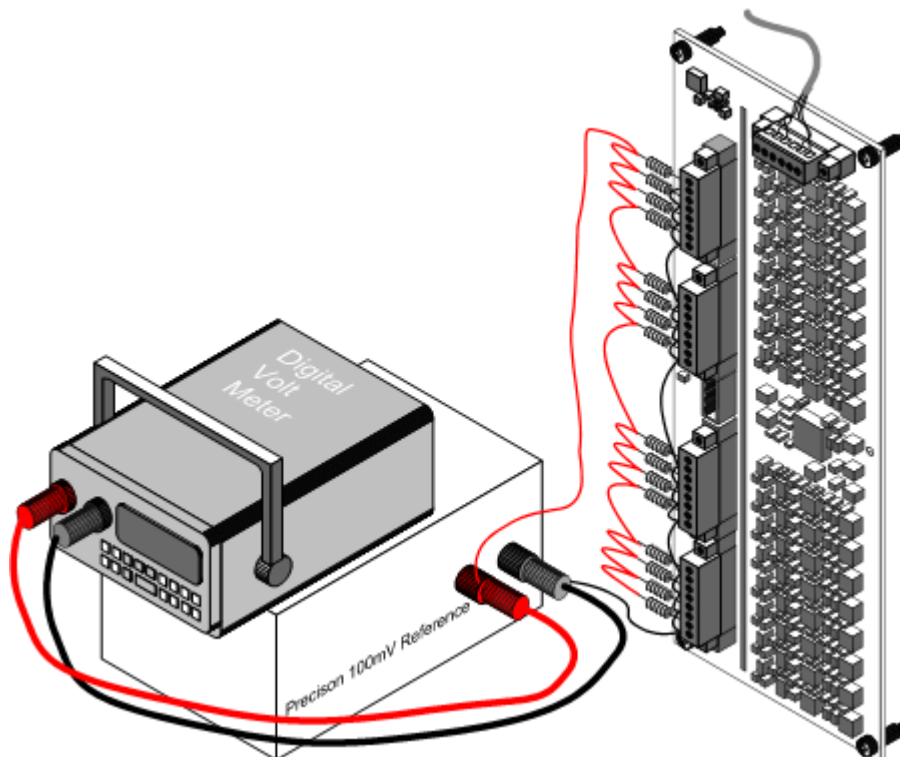

Figure 8.4 Pictorial Diagram of LLMUX2 TC Calibration Setup



8.2.2 LLMUX2 RTD Calibration

There are no adjustments on the LLMUX2 RTD subsystem for calibration purposes. Calibration in the field is not recommended. However, if you decide to perform calibration, the setup for the

LLMUX2 RTD is covered here. Note that there was no calibration procedure for the older LLMUX RTD FTAs. Therefore this setup procedure is not a modification of an older procedure—it is a new setup procedure. In the new setup procedure, a precision 400 ohm 0.01 % resistor must be connected to *each* channel. Figure 5-5 shows the connections required to perform the calibration operation. Figure 5-6 shows a pictorial diagram of the LLMUX2 RTD calibration setup.

After the setup is completed, the calibration is initiated from the Low Level Multiplexer IOP Detail Status Display. The procedure for initiating calibration is covered in the *High-Performance Process Manager Service* and the *Process Manager/Advanced Process Manager Service* manuals and is not repeated here. The procedure covered in those manuals is for the calibration of the TC version of LLMUX, but the same procedure is used to initiate calibration for the RTD version of the LLMUX2.

The calibration process involves the FTA reading the precision source and then storing this data in non-volatile EEPROM on the FTA.

Figure 8.5 Connection Diagram for LLMUX2 RTD Calibration

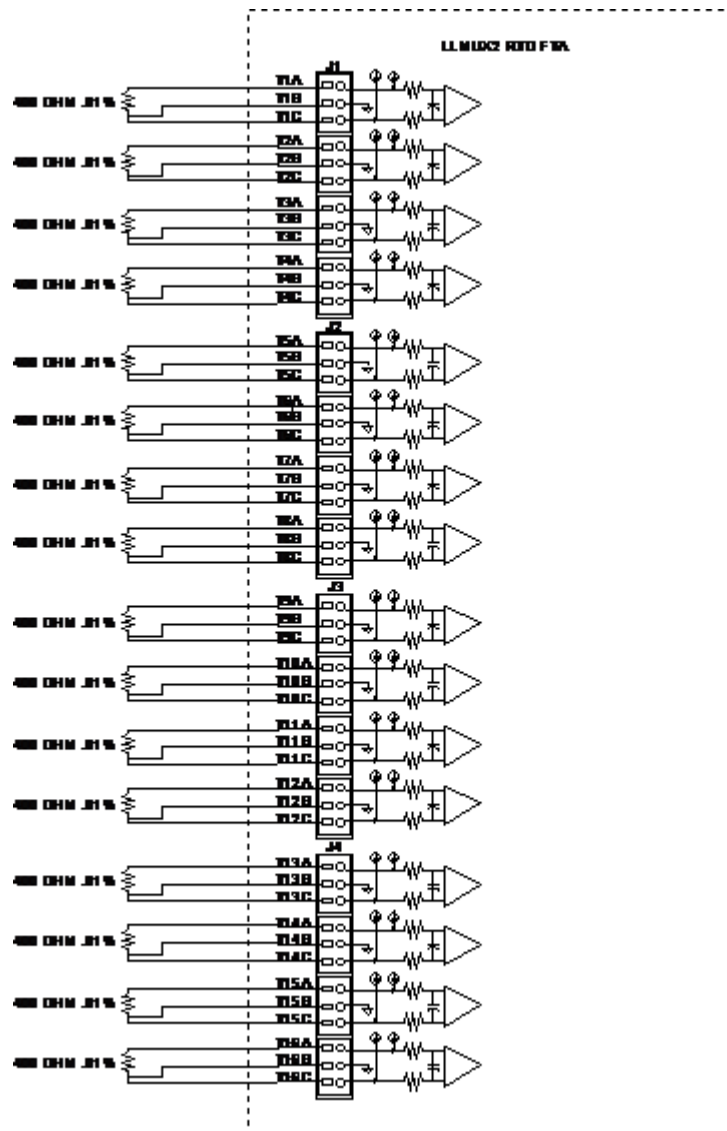
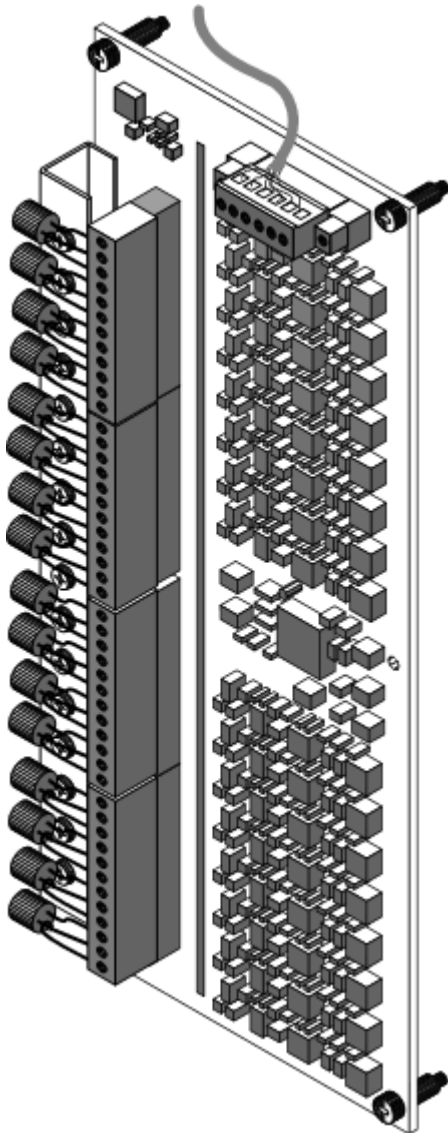

Figure 8.6 Pictorial Diagram of LLMUX2 RTD Calibration Setup



Notices

Trademarks

Experion®, PlantScape®, SafeBrowse®, TotalPlant®, and TDC 3000® are registered trademarks of Honeywell International, Inc.

ControlEdge™ is a trademark of Honeywell International, Inc.

OneWireless™ is a trademark of Honeywell International, Inc.

Matrikon® and MatrikonOPC™ are trademarks of Matrikon International. Matrikon International is a business unit of Honeywell International, Inc.

Movilizer® is a registered trademark of Movilizer GmbH. Movilizer GmbH is a business unit of Honeywell International, Inc.

Other trademarks

Microsoft and SQL Server are either registered trademarks or trademarks of Microsoft Corporation in the United States and/or other countries.

Trademarks that appear in this document are used only to the benefit of the trademark owner, with no intention of trademark infringement.

Third-party licenses

This product may contain or be derived from materials, including software, of third parties. The third party materials may be subject to licenses, notices, restrictions and obligations imposed by the licensor. The licenses, notices, restrictions and obligations, if any, may be found in the materials accompanying the product, in the documents or files accompanying such third party materials, in a file named third_party_licenses on the media containing the product, or at <http://www.honeywell.com/ps/thirdpartylicenses>.

Documentation feedback

You can find the most up-to-date documents on the Honeywell Process Solutions support website at: <http://www.honeywellprocess.com/support>

If you have comments about Honeywell Process Solutions documentation, send your feedback to: hpsdocs@honeywell.com

Use this email address to provide feedback, or to report errors and omissions in the documentation. For immediate help with a technical problem, contact your local Honeywell Process Solutions Customer Contact Center (CCC) or Honeywell Technical Assistance Center (TAC).

How to report a security vulnerability

For the purpose of submission, a security vulnerability is defined as a software defect or weakness that can be exploited to reduce the operational or security capabilities of the software.

Honeywell investigates all reports of security vulnerabilities affecting Honeywell products and services.

To report a potential security vulnerability against any Honeywell product, please follow the instructions at:

<https://www.honeywell.com/product-security>

Support

For support, contact your local Honeywell Process Solutions Customer Contact Center (CCC). To find your local CCC visit the website, <https://www.honeywellprocess.com/en-US/contact-us/customer-support-contacts/Pages/default.aspx>.

Training classes

Honeywell holds technical training classes that are taught by process control systems experts. For more information about these classes, contact your Honeywell representative, or see <http://www.automationcollege.com>.